

Mountain Top® Roll

Owner's manual, Ford Ranger Wildtrak

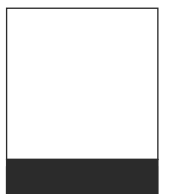



1.	Conditions of use.....	p. 2
2.	Warnings.....	p. 4
3.	Functions.....	p. 5
4.	Release locking system.....	p. 6
5.	Spring adjustment.....	p. 8
6.	Maintenance	
6.1	General cleaning.....	p. 9
6.2	Cleaning the canister.....	p. 10
6.3	Lubrication.....	p. 11
6.4	Re-tightening the bolts.....	p. 12

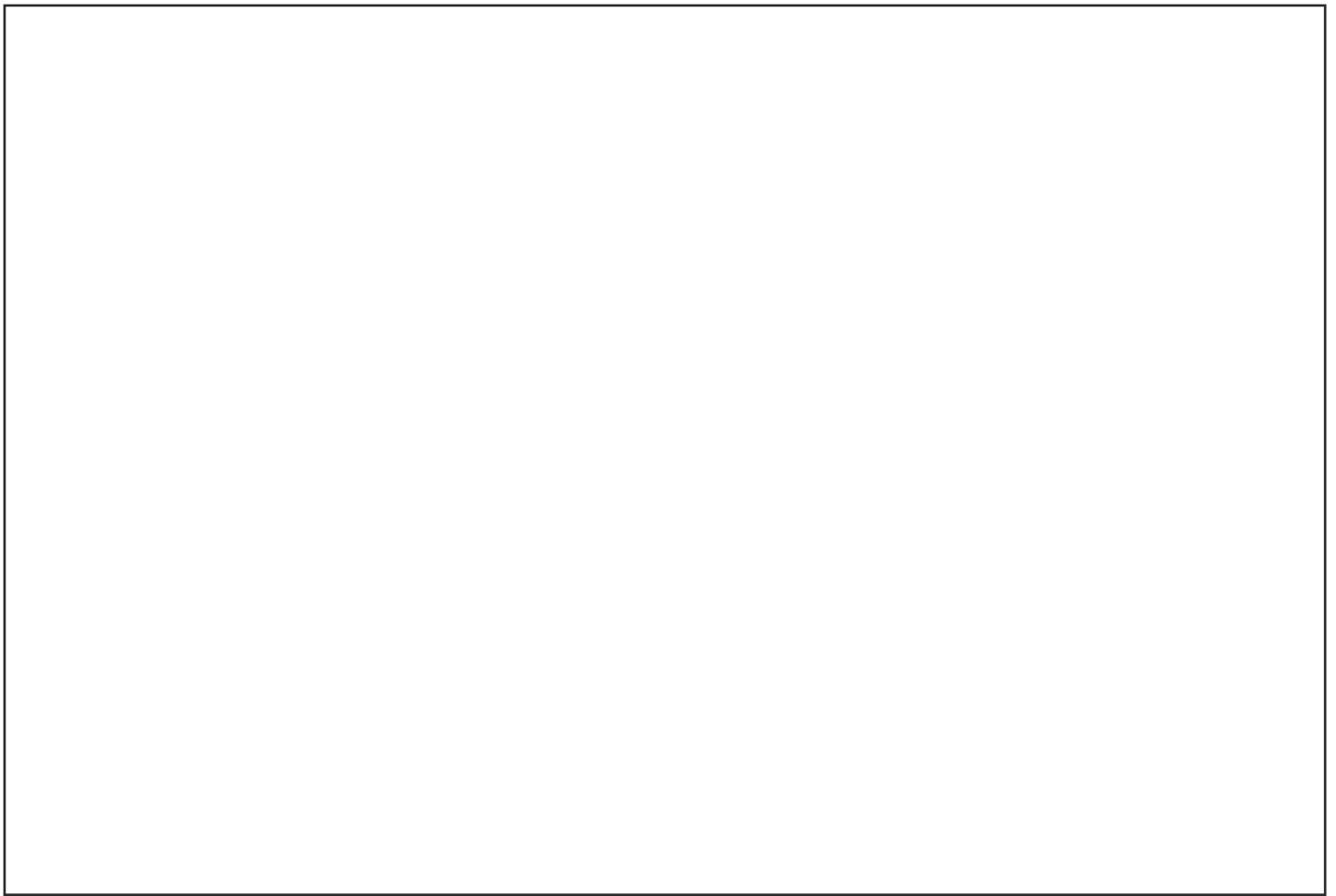

1 Conditions of use

- The Mountain Top Roll cover is made of aluminium, plastics, and rubber.
- To ensure a smooth and trouble free operation, it's advised to follow this manual.
- The Mountain Top Roll cover has been designed for normal driving conditions on roads; the design is lightweight and not suitable for extreme usage.
- Temperature range: -30 to +80 degrees Celsius.
- The purpose of The Mountain Top Roll cover is to cover the bed from rain and dirt:
 - Designed to withstand rain water, some water ingress may occur. In the tailgate area there will be water ingress.
- The Mountain Top Roll is made of aluminium profiles which heats up and cools down relatively quick according to weather conditions. This can cause condensation on the underside of the lamellas and the panels.

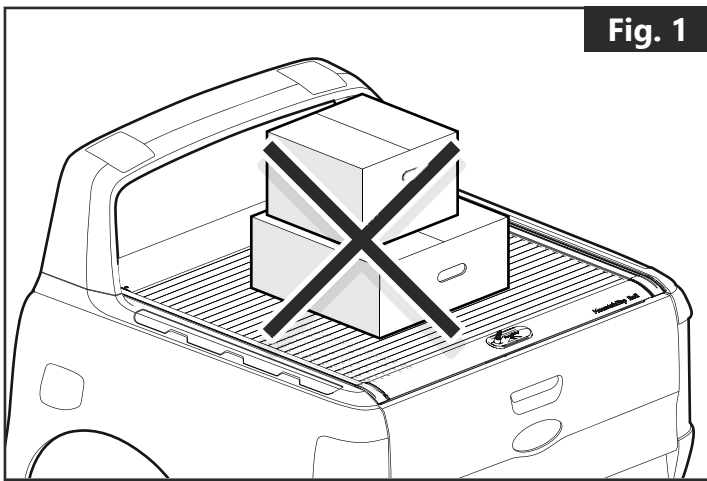

Fig. 1

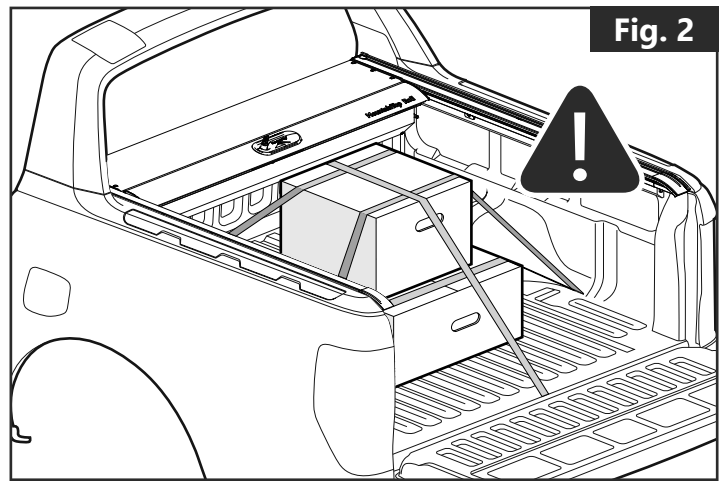

Fig. 2

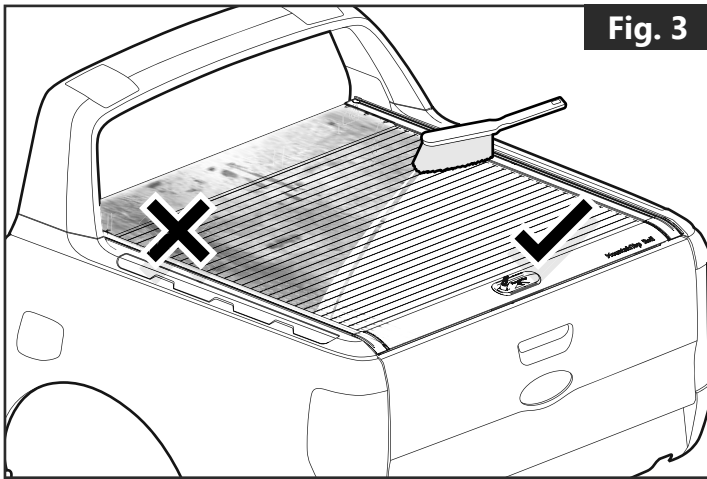

Fig. 3

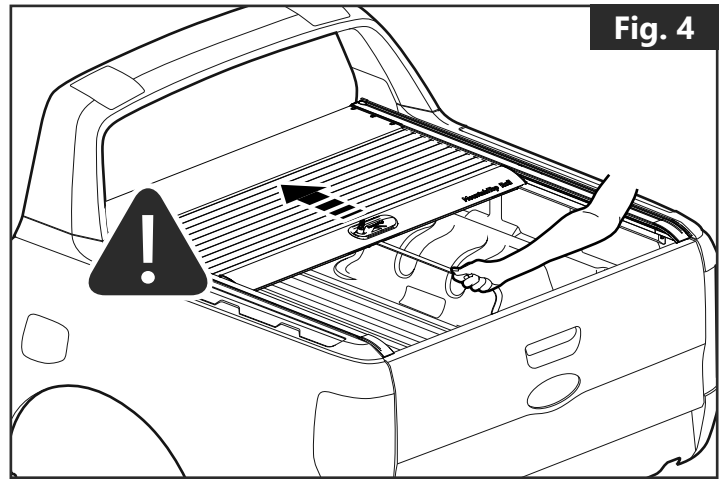
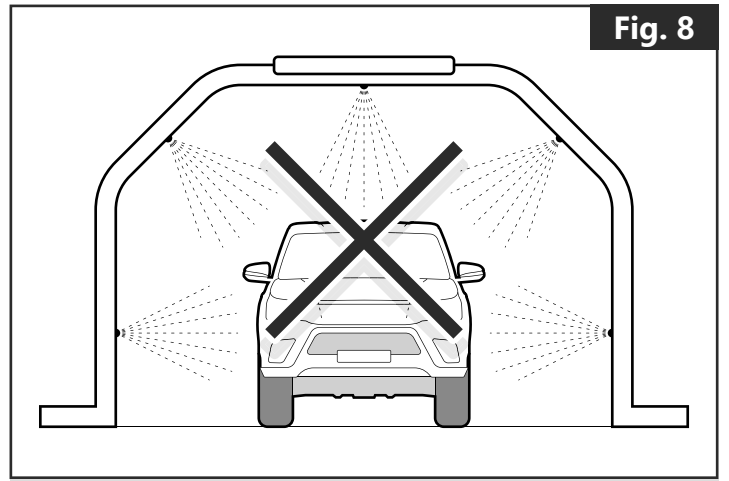
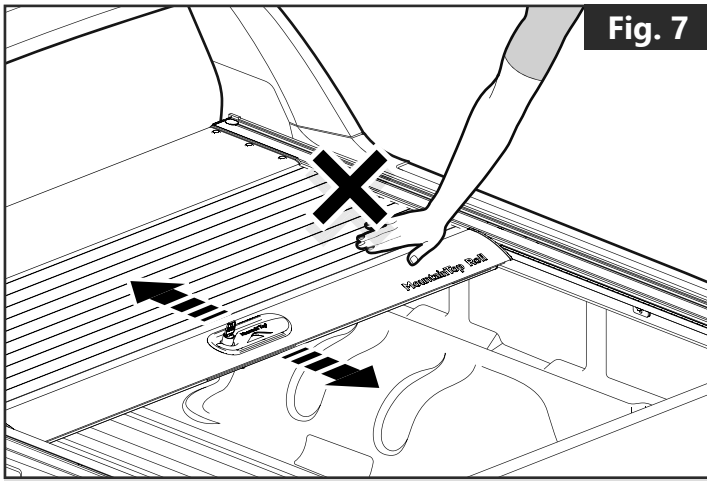
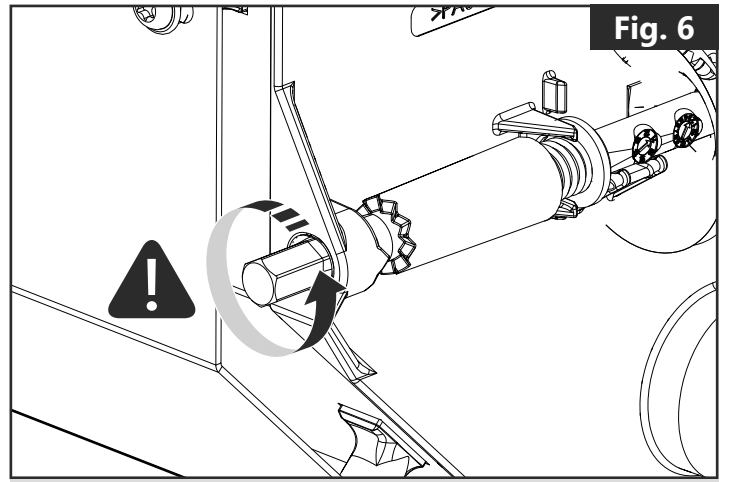
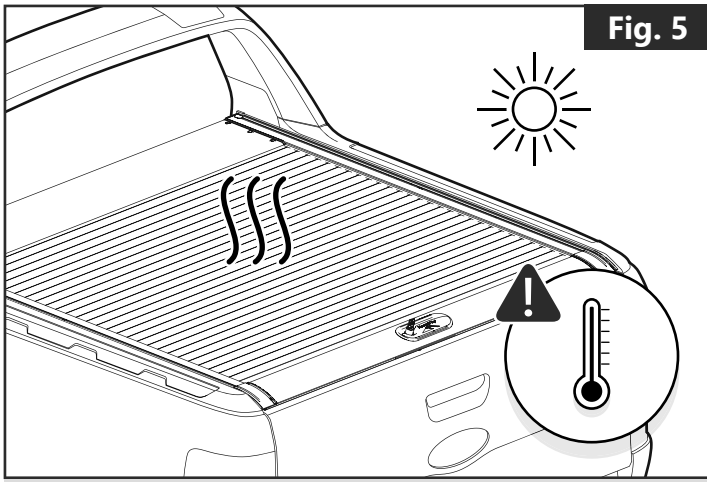

Fig. 4

- The Roll cover is not designed for loading although it can support normal snow loads. No part of it can support any load from cargo or persons and the product might be damaged if somebody stands on it. **(Fig. 1)**
- The Mountain Top Roll is NOT a 100% waterproof product, but offers good protection against the elements. It is weather resistant, meaning that some water leakage must be expected.
- The pull strap has been designed only for opening and closing the Roll cover. The carabineer and ring will be damaged in case of excessive load.
- Goods in the bed must be secured during transportation to prevent damage on the structural parts of Roll cover (especially the canister). **(Fig. 2)**
- If the Roll cover is closed and has water, snow, ice or dirt on the cover, it might enter into the bed as the cover retracts. To avoid this, clean off the top surface of the cover prior to opening. **(Fig. 3)**
- When opening the cover, the opening should be careful and controlled using the pull strap to prevent the cover from hitting the front with full speed, which it has NOT been designed for. **(Fig. 4)**



2 Warnings

- Do not drive with persons under the Roll cover.
- Do not allow persons or animals to stay in the bed when the cover is closed.
- Temperatures can be very high under the cover when closed. **(Fig. 5)**
- The pull strap should not be used to tie down cargo.
- Do not disassemble the main shaft from the canister without relieving the spring tension completely (See "Spring adjustment"). **(Fig. 6)**
- Remove fingers from lamellas when opening and closing. **(Fig. 7)**
- We do not recommend washing the Roll cover in a brushless carwash, as the coating may be damaged due to use of chemicals. **(Fig. 8)**
- Wash the Roll cover regularly using normal car shampoo and a soft, lint free cloth or brush.
- If washed in any carwash, or if any chemicals are used on the roll cover, please ensure a max PH value of 8 is used, to avoid damage to the coating.

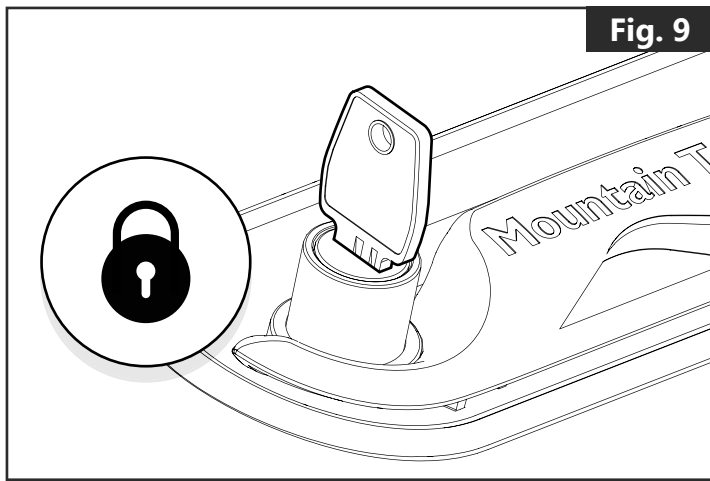

Fig. 9

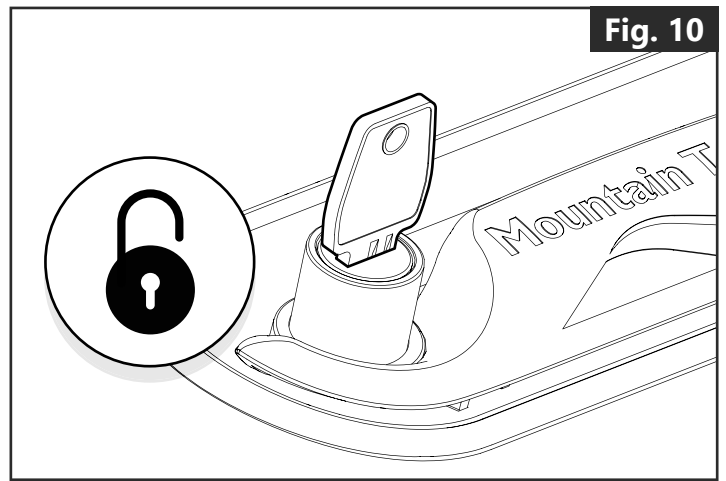

Fig. 10

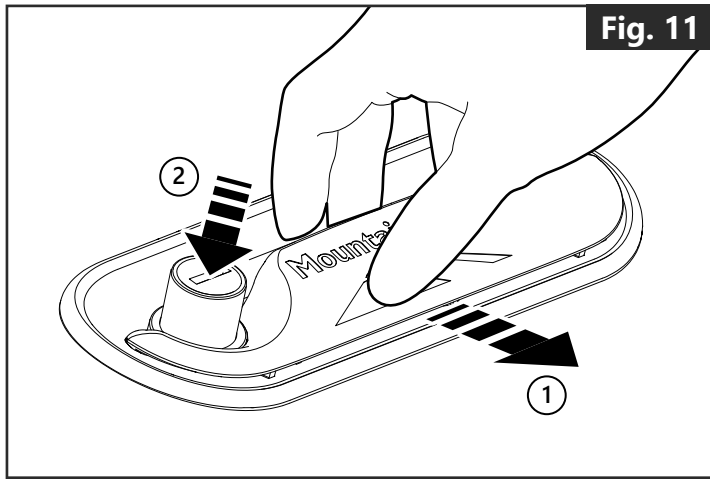

Fig. 11

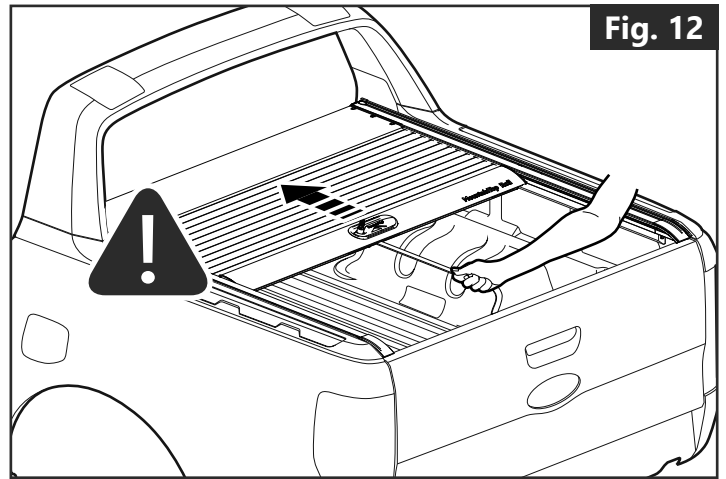
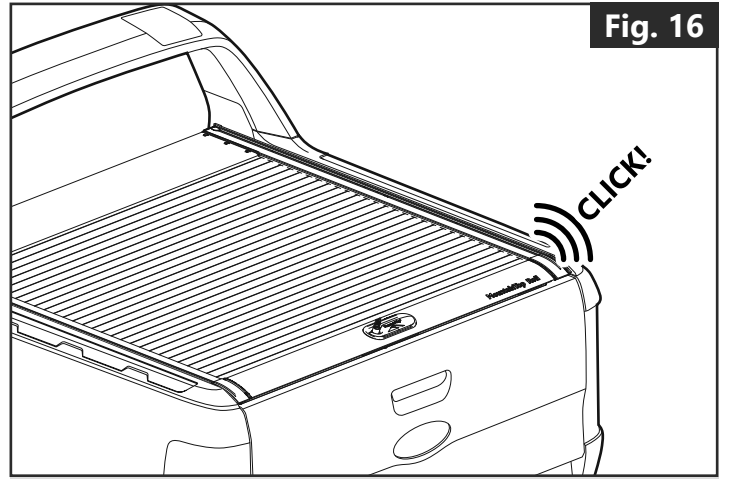
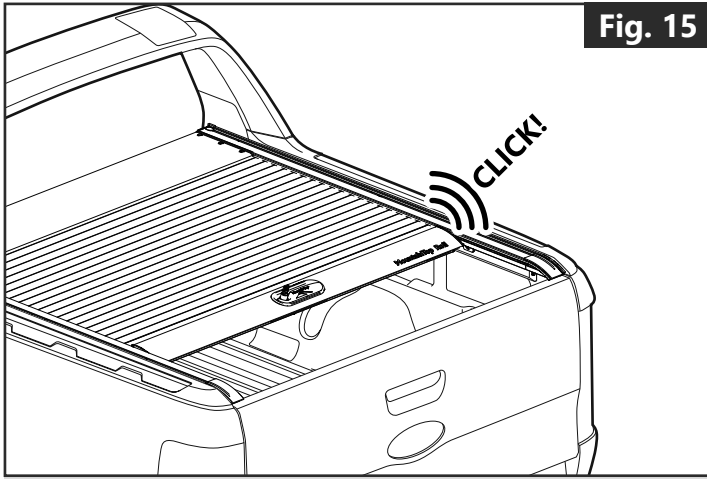
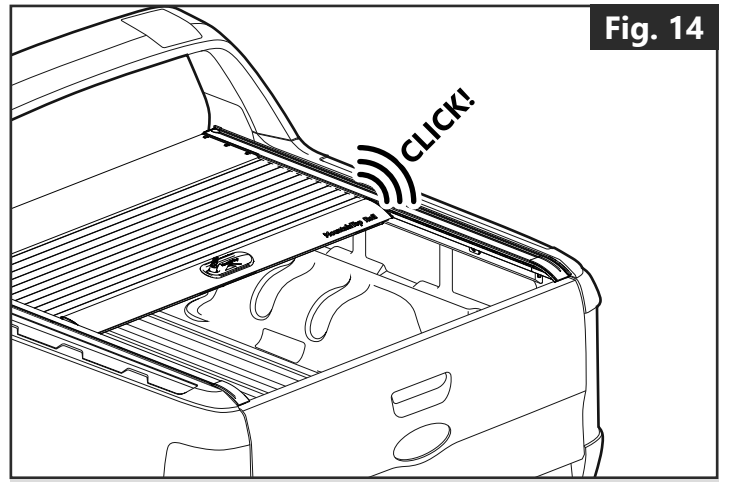
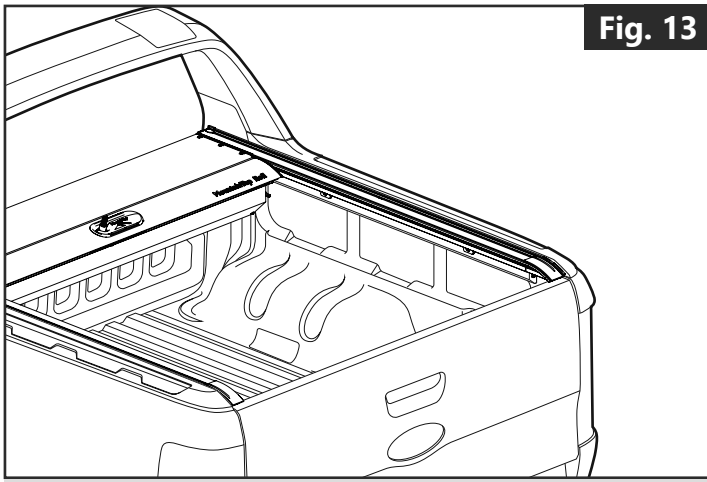

Fig. 12

3 Functions

- To open The Mountain Top Roll cover:
 - Make sure the Roll cover is unlocked (**Fig. 9+10**)
 - Pull back on the handle, and press down on the lock cylinder. The lock is now disengaged, and can be moved. (**Fig. 11**)
 - Use the pull strap to gently open the Roll cover to any position, as long as the lock is not engaged. (**Fig. 12**)
- To move the cover forward to an open position requires use of the locking function, although the cover can be moved rearwards to closing position without operating the locking function.
- Engage the lock again by either going to the fully open position, or by using the pull strap to engage the lock. (**Fig. 17**)



4 Release locking system

- The Mountain Top Roll cover features a locking system with multiple locking points along the profiles. The Roll cover will stop at the locking points only when the lock is engaged.
- When the locking system is engaged, the Roll cover will lock in these 4 positions:
 - Fully open. (**Fig. 13**)
 - 2/3 open. (**Fig. 14**)
 - 1/3 open. (**Fig. 15**)
 - Fully closed. (**Fig. 16**)
- To fully open the Roll cover, the locking system must be disengaged.

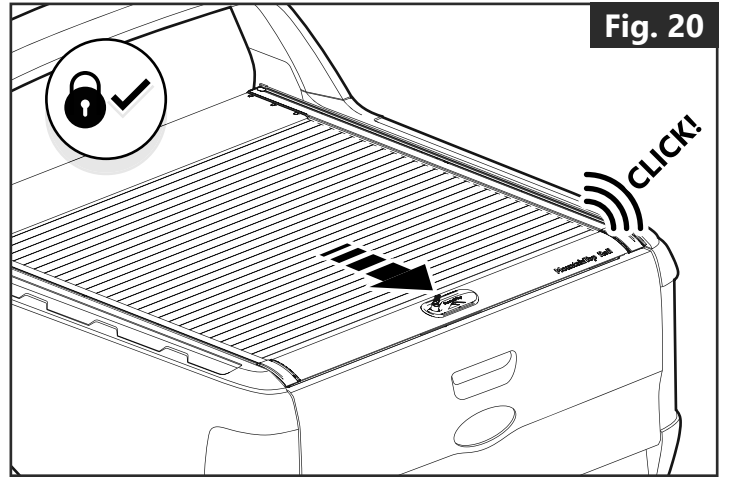
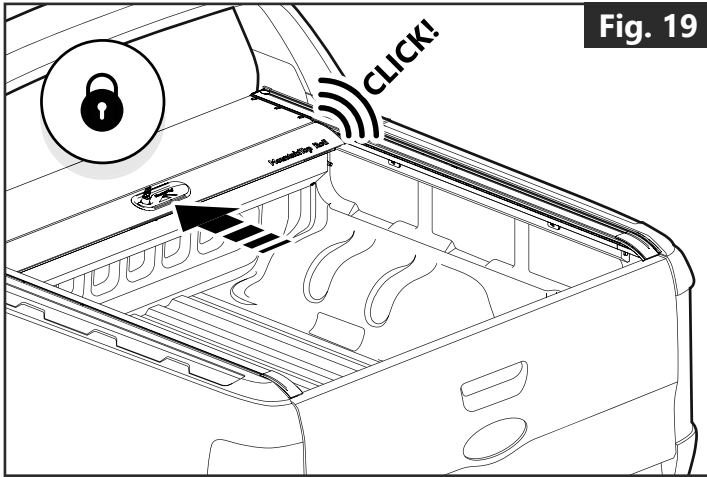
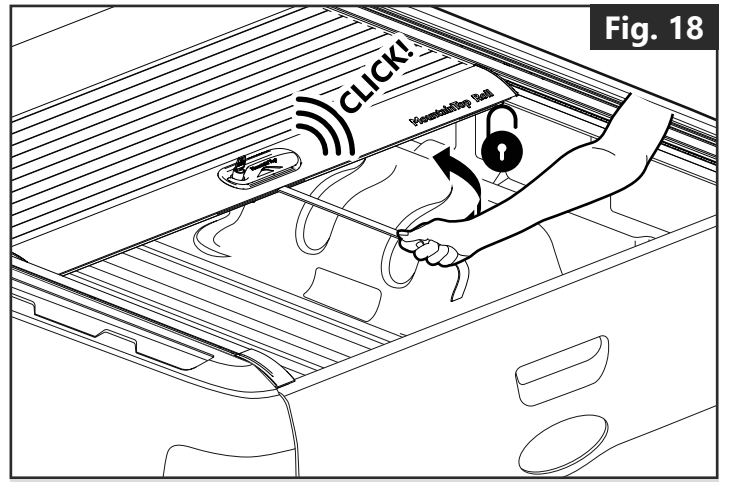
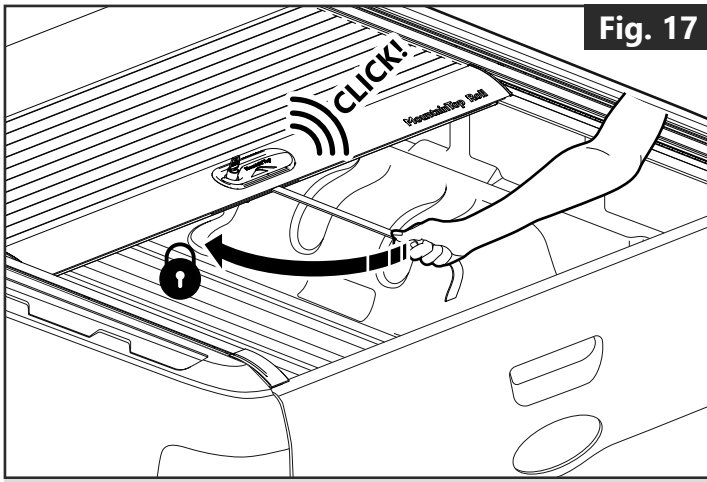

- To toggle the locking system, pull the strap either left (**engage**) or right (**disengage**). (**Fig. 17+18**)
- When the Roll cover is fully opened, a lock activator is automatically triggered, engaging the locking system. (**Fig.19**)
- For the Roll cover to close correctly, the locking system must be engaged before the cover is closed. (**Fig. 20**)

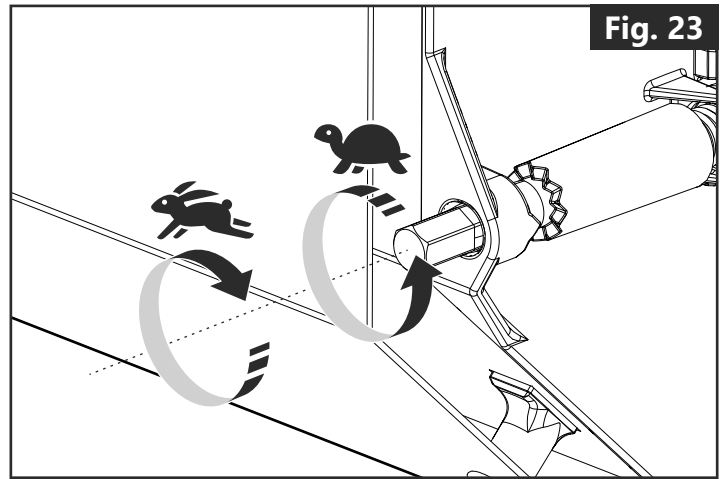
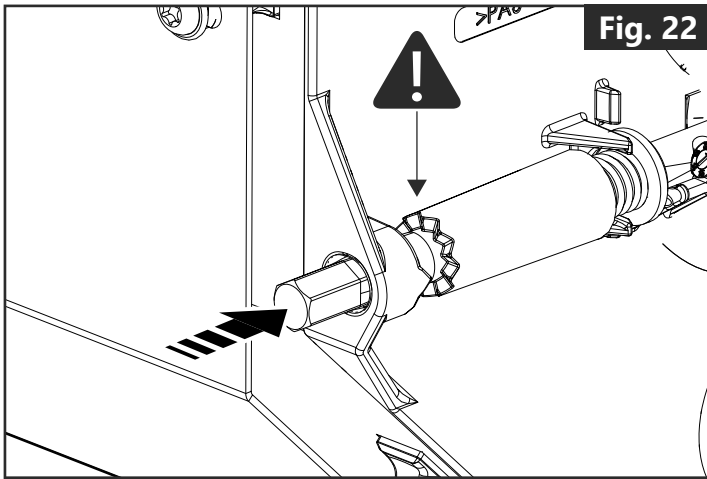
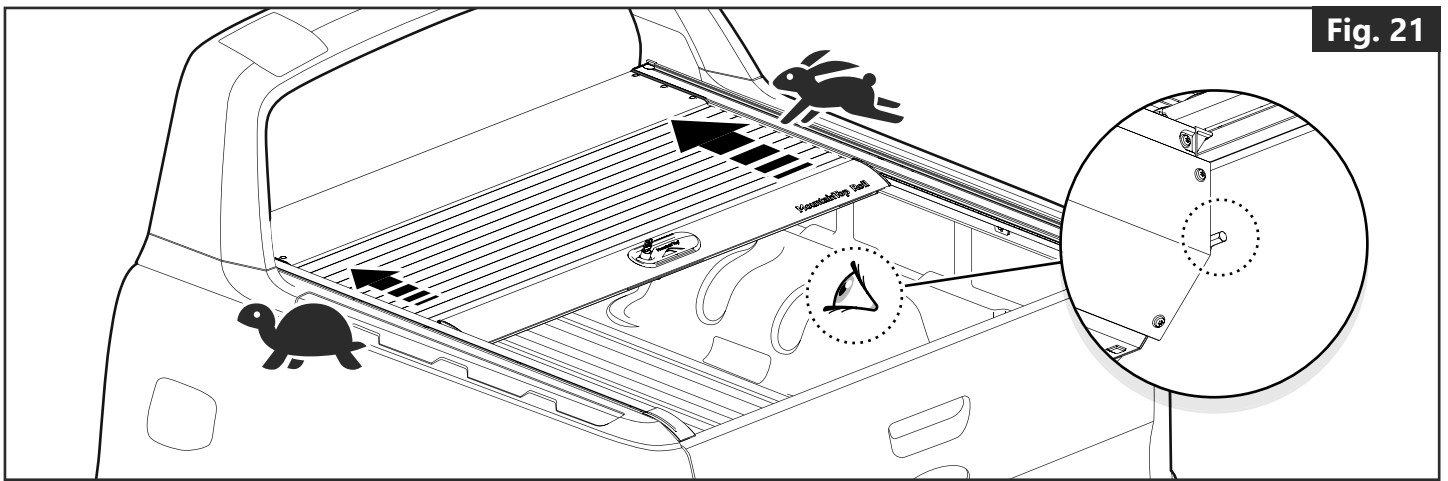

5 Spring adjustment

- Before adjusting the spring, make sure the Roll cover is cleaned and lubricated properly.
- The main spring is positioned in the main shaft in the canister. The spring tension has been adjusted by delivery and is ready to use.

Spring tension can easily be adjusted. At the right side of the canister end piece there is a pinion. **(Fig. 21)** To adjust the tension:

- Press the shaft inward to release the locking mechanism. Use a small wrench with an 8 mm key: **(Fig. 22)**
 - While maintaining pressure on the shaft, adjust clockwise to increase spring tension and make the Roll cover open faster **(Fig. 23)**
 - While maintaining pressure on the shaft, adjust anticlockwise to reduce spring tension and make the Roll cover open slowly **(Fig. 23)**
- **WARNING** - The main spring may cause injury if the canister is opened without relieving the spring tension.

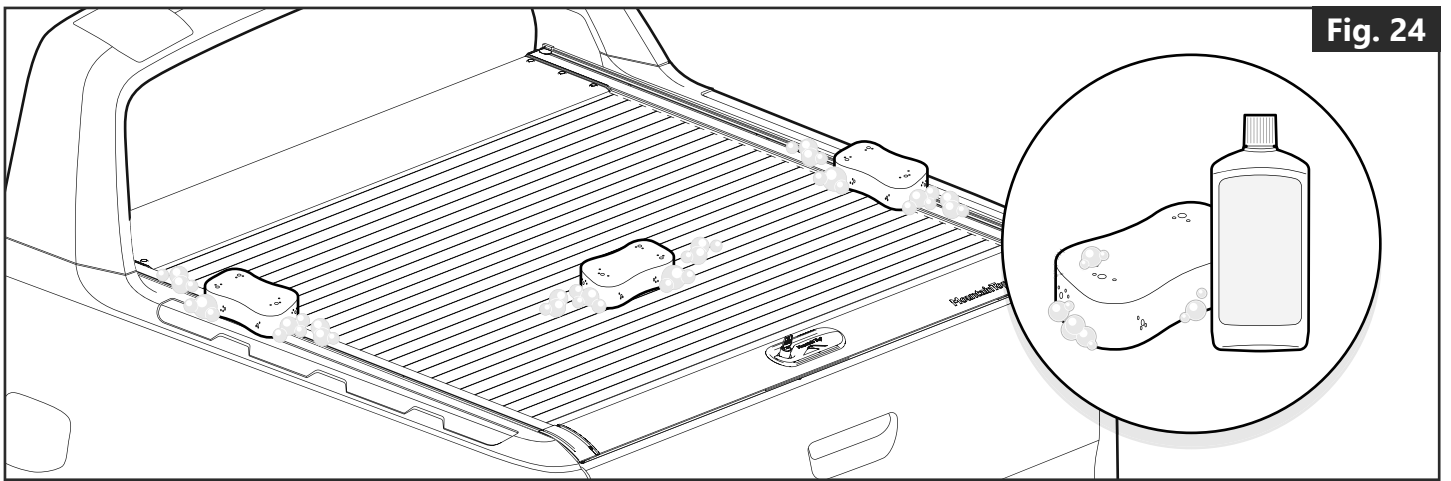

Fig. 24

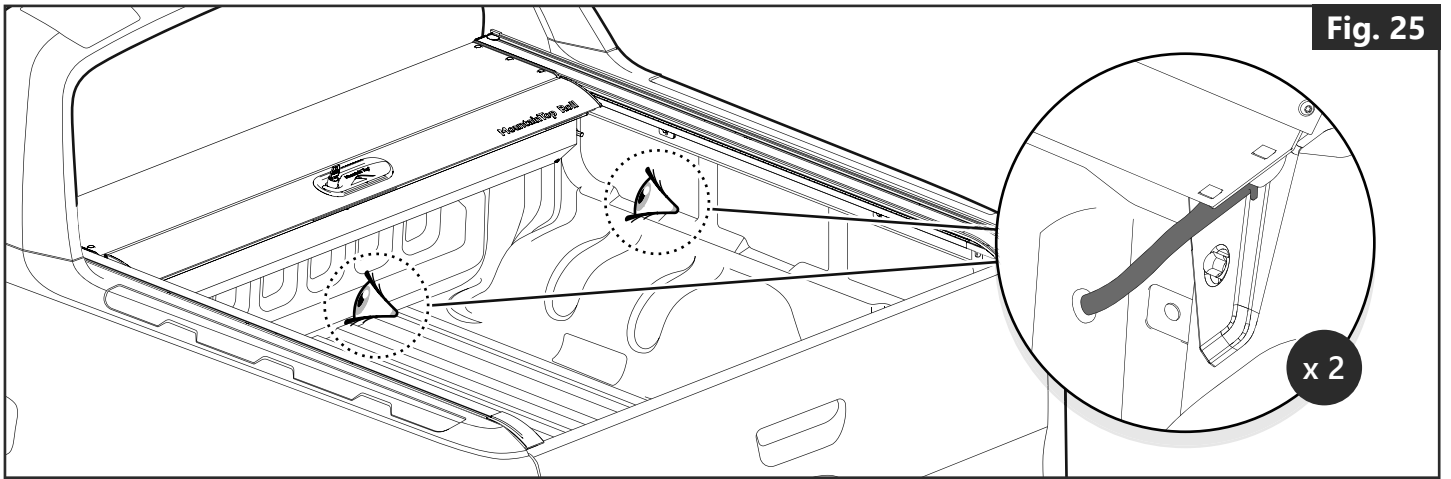

Fig. 25

6.1 General cleaning

- The Roll cover should be cleaned on a regular basis using water with normal car shampoo (PH < 8). **(Fig. 24)**

Drains should be cleaned often to ensure proper function of water management

- **(Fig. 25)**

When cleaning, use a soft, lint free cloth or brush. Rinse soap foam off thoroughly with

- fresh water, and dry with a clean cloth. It is vital that any other chemicals such as petrol, strong alkaline or acid are NOT used on the surface.

Do not use abrasive cleaning tools such as steel wool, hard brushes, abrasive scourers, as

- these may damage the coating surface and change the color or gloss levels of the finish.

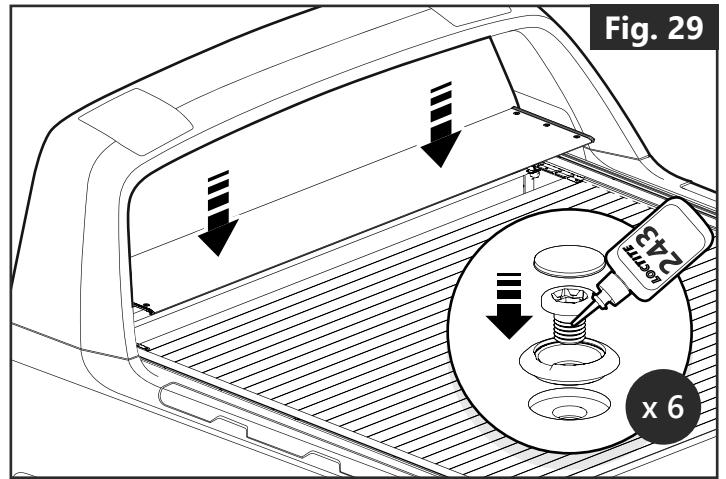
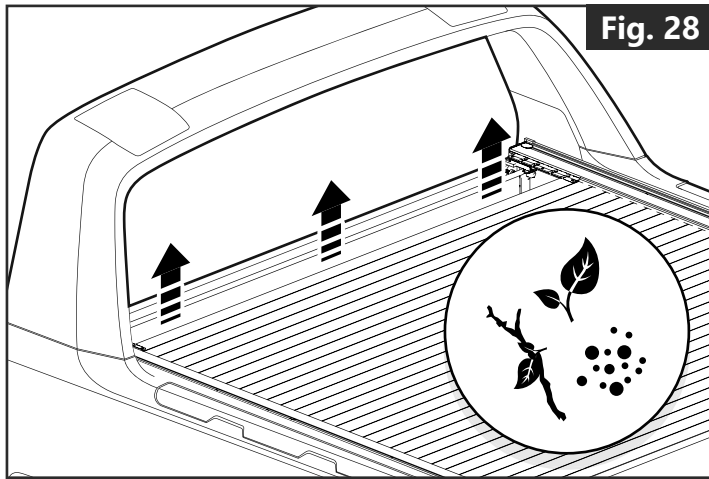
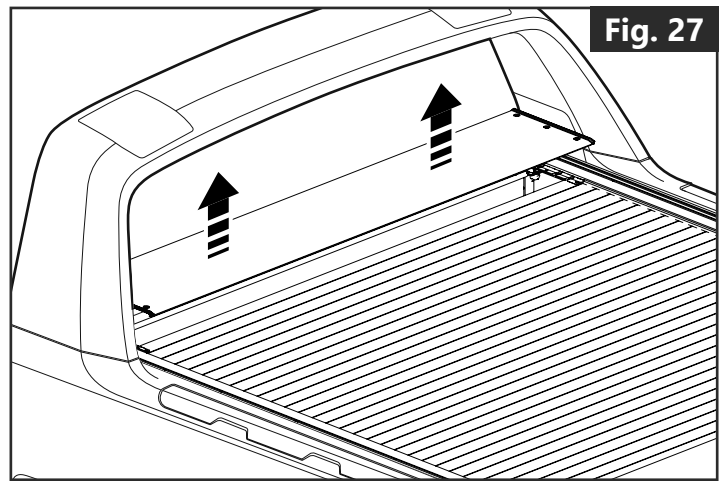
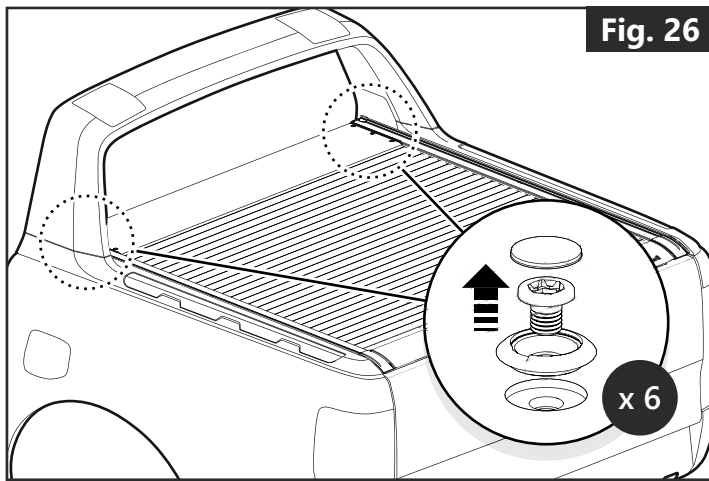

6.2 Cleaning the canister

- The canister should be cleaned at least once a year removing dirt and debris. The lid over the canister needs to be removed for this operation and should be carefully reassembled. Take care not to lose the plastic screw caps
 - Remove the 6 screws on the lid. Take care not to lose them. **(Fig. 26)**
 - Remove the lid. **(Fig. 27)**
 - Remove dirt and debris from the canister. **(Fig. 28)**
 - Reassemble the lid, using a drop of e.g. **Locktite 243** and a torque wrench at **1,8 Nm**. **(Fig. 29)**

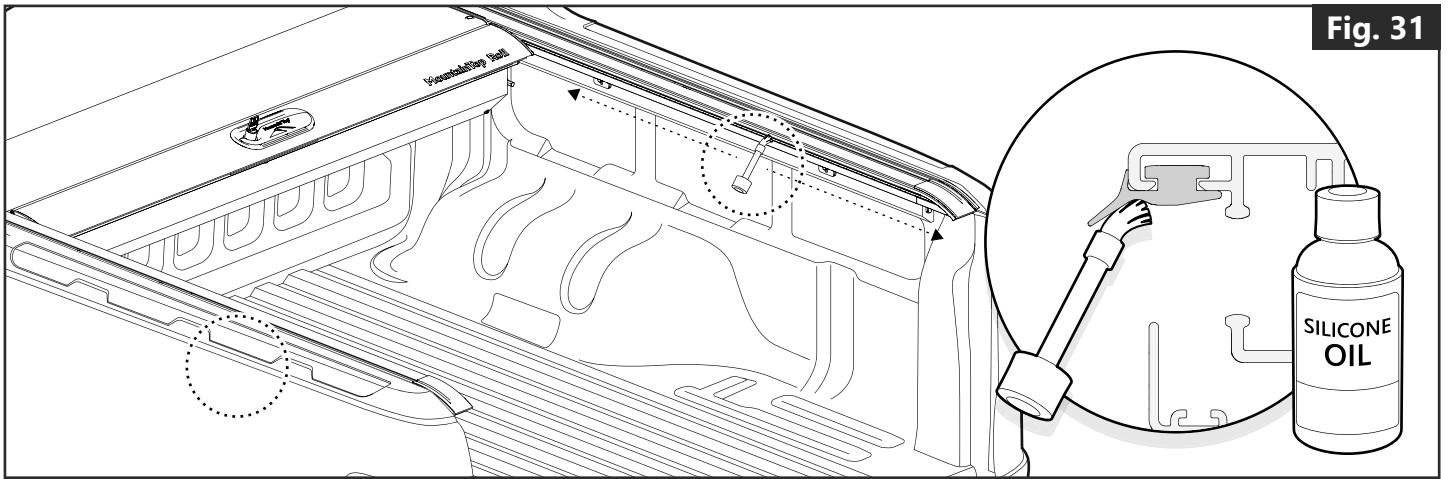
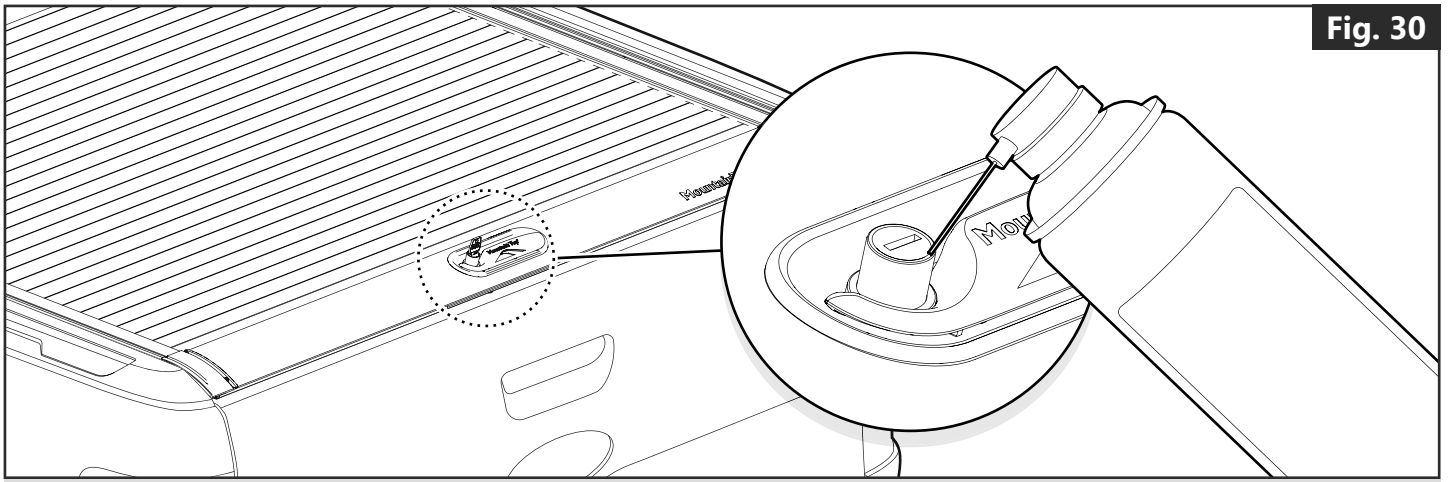

6.3 Lubrication

- The lock should be lubricated regularly using a suitable lock lubricant (e.g. Würth lock spray), or similar. **(Fig. 30)**
- Seals and side profiles should be cleaned and lubricated regularly using silicone (e.g. Würth Silicone Oil), or similar. **(Fig. 31)**

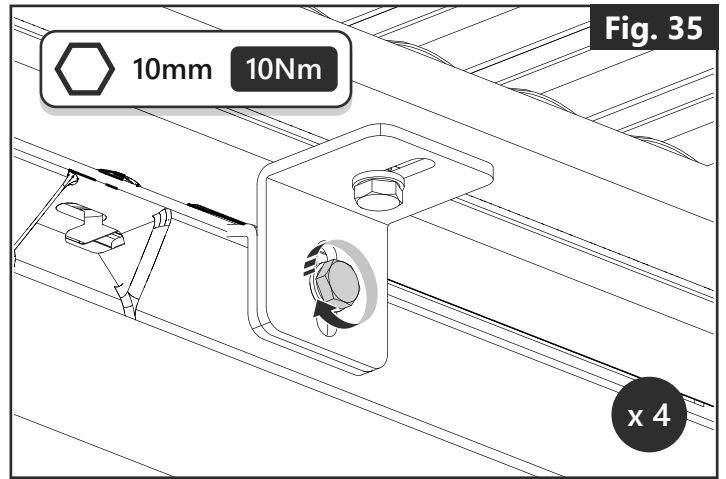
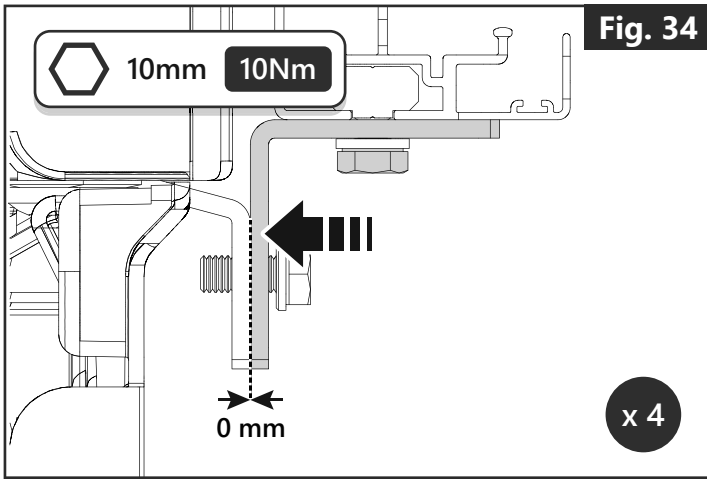
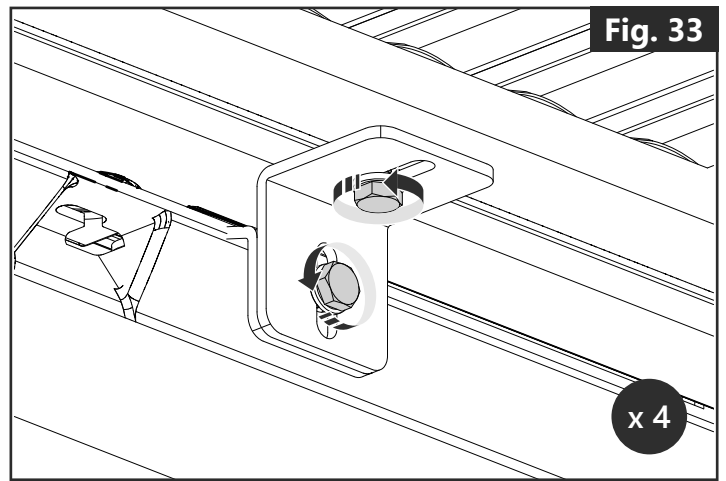
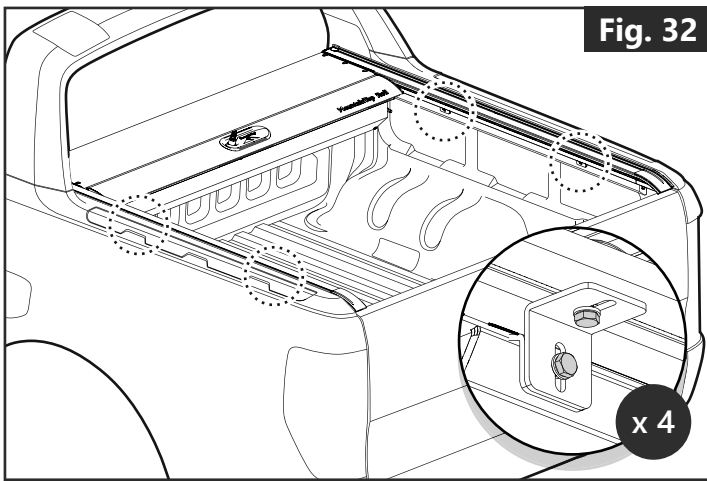

6.4 Re-tightening the bolts

- Over time, some of the bolts may loosen due to vibrations. To re-tighten the bolts correctly, first locate the 4 angle brackets underneath the side rails (*fig. 32*):
 - Loosen bolts on the side rail brackets slightly. The brackets should be able to move freely (*fig. 33*).
 - Tighten the remaining bolts by first positioning the brackets as shown, and tighten the top bolts using a torque wrench to **10 Nm** (*fig. 34*).
 - Tighten lower bolts to **10 Nm** (*fig. 35*).
- To prevent the bolts loosening again, remove the bolts and apply Loctite. Fasten the bolts again using the method above (*fig. 33-35*).



Kraftfahrt-Bundesamt

DE-24932 Flensburg

Allgemeine Betriebserlaubnis (ABE) National Type Approval

ausgestellt von:

Kraftfahrt-Bundesamt (KBA)

nach § 22 in Verbindung mit § 20 Straßenverkehrs-Zulassungs-Ordnung (StVZO)
für einen Typ des folgenden Genehmigungsobjektes

Laderaumabdeckung

issued by:

Kraftfahrt-Bundesamt (KBA)

according to § 22 and 20 Straßenverkehrs-Zulassungs-Ordnung (StVZO) for a type
of the following approval object

loading bay cover/ tanneau cover

Nummer der Genehmigung: **91318**
Approval No.

Erweiterung Nr.: **06**
Extension No.:

1. Genehmigungsinhaber:
Holder of the approval:
MOUNTAIN TOP INDUSTRIES ApS
DK-3600 Frederikssund
2. Gegebenenfalls Name und Anschrift des Bevollmächtigten:
If applicable, name and address of representative:
entfällt
not applicable
3. Typbezeichnung:
Type:
Mountain Top Roll



Kraftfahrt-Bundesamt

DE-24932 Flensburg

3

Nummer der Genehmigung: **91318**
Approval No.

Erweiterung Nr.: **06**
Extension No.:

10. Bemerkungen:
Remarks:
**Es gelten die im o.g. Gutachten nebst Anlagen festgehaltenen Angaben.
The indications given in the above mentioned test report including its annexes shall apply.**
11. Änderungsabnahme gemäß § 19 (3) StVZO:
Acceptance test of the modification as per § 19 (3) StVZO:
**nicht notwendig
not required**
12. Die Genehmigung wird **erweitert**
Approval **extended**
13. Grund (Gründe) für die Erweiterung der Genehmigung (falls zutreffend):
Reason(s) for the extension (if applicable):
**eine weitere Ausführung kommt hinzu
a further version is added**
14. Ort: **DE-24932 Flensburg**
Place:
15. Datum: **14.09.2017**
Date:
16. Unterschrift: **Im Auftrag**
Signature:

Kevin Eckmann





Kraftfahrt-Bundesamt

DE-24932 Flensburg

Nummer der Genehmigung: **91318 06**

- Anlage -

Nebenbestimmungen und Rechtsbehelfsbelehrung

Nebenbestimmungen

Jede Einrichtung, die dem genehmigten Typ entspricht, ist gemäß der angewendeten Vorschrift zu kennzeichnen.

Das Genehmigungszeichen lautet wie folgt:

KBA 91318

Die Einzelerzeugnisse der reihenweisen Fertigung müssen mit den Genehmigungsunterlagen genau übereinstimmen. Änderungen an den Einzelerzeugnissen sind nur mit ausdrücklicher Zustimmung des Kraftfahrt-Bundesamtes gestattet.

Änderungen der Firmenbezeichnung, der Anschrift und der Fertigungsstätten sowie eines bei der Erteilung der Genehmigung benannten Zustellungsbevollmächtigten oder bevollmächtigten Vertreters sind dem Kraftfahrt-Bundesamt unverzüglich mitzuteilen.

Verstöße gegen diese Bestimmungen können zum Widerruf der Genehmigung führen und können überdies strafrechtlich verfolgt werden.

Die Genehmigung erlischt, wenn sie zurückgegeben oder entzogen wird, oder der genehmigte Typ den Rechtsvorschriften nicht mehr entspricht. Der Widerruf kann ausgesprochen werden, wenn die für die Erteilung und den Bestand der Genehmigung geforderten Voraussetzungen nicht mehr bestehen, wenn der Genehmigungsinhaber gegen die mit der Genehmigung verbundenen Pflichten - auch soweit sie sich aus den zu dieser Genehmigung zugeordneten besonderen Auflagen ergeben - verstößt oder wenn sich herausstellt, dass der genehmigte Typ den Erfordernissen der Verkehrssicherheit oder des Umweltschutzes nicht entspricht.

Das Kraftfahrt-Bundesamt kann jederzeit die ordnungsgemäße Ausübung der durch diese Genehmigung verliehenen Befugnisse, insbesondere die genehmigungsgerechte Fertigung sowie die Maßnahmen zur Übereinstimmung der Produktion, nachprüfen. Es kann zu diesem Zweck Proben entnehmen oder entnehmen lassen. Dem Kraftfahrt-Bundesamt und/oder seinen Beauftragten ist ungehinderter Zutritt zu Produktions- und Lagerstätten zu gewähren.

Die mit der Erteilung der Genehmigung verliehenen Befugnisse sind nicht übertragbar. Schutzrechte Dritter werden durch diese Genehmigung nicht berührt.

Rechtsbehelfsbelehrung

Gegen diese Genehmigung kann innerhalb eines Monats nach Bekanntgabe Widerspruch erhoben werden. Der Widerspruch ist beim **Kraftfahrt-Bundesamt, Fördestraße 16, DE-24944 Flensburg**, schriftlich oder zur Niederschrift einzulegen.

zur Erteilung eines Nachtrags zur ABE 91318 05
nach § 22 in Verbindung mit § 20 Straßenverkehrs-Zulassungs-Ordnung StVZO
*For the application of an amendment to German National Type Approval 91318*05
according to § 22 in connection with § 20 StVZO German Federal Road Traffic Standards)*

Fahrzeugteilart / <i>Vehicle part</i>	:	Laderaumabdeckung / <i>loading bay cover</i>
Typ / <i>type</i>	:	Mountain Top Roll
Antragsteller / <i>applicant</i>	:	Mountain Top Industries ApS, DK-3600 Frederikssund

1. Der genannte Fahrzeugteiletyp wird vom Antragsteller im eigenen Betrieb DK-3600 Frederikssund gefertigt.

The vehicle part is manufactured by the applicant in the company's own plant in DK-3600 Frederikssund, Denmark.

2. Der Antragsteller ermöglicht aufgrund von technischen Fachkräften, Fertigungsanlagen und Kontrolleinrichtungen eine gleichmäßige, reihenweise Fertigung von Fahrzeugteilen des in der Typbeschreibung festgelegten Fahrzeugteiletyps.

Based upon the existing technical expert staff, production plants and controls, the applicant is able to produce vehicle parts in series with proven constant quality of the vehicle part which is described in the technical description sheets.

Tatsachen, die die Zuverlässigkeit des Antragstellers im Sinne des § 20 StVZO in Frage stellen, sind hier nicht bekannt.

Facts that could lead to doubts of credibility of the applicant with respect to § 20 StVZO are unknown here.

3. Die beigefügte Typbeschreibung besteht aus Blatt 1 bis 5 und ist mit den darin unter Ziffer 5. angegebenen Anlagen Bestandteil des Gutachtens.

The enclosed description sheets consist of pages 1 to 5 and, together with the attachments listed under section 5, are part of this test report

4. Der Fahrzeugteiletyp entspricht der vollständigen Typbeschreibung und genügt den heute gültigen Bestimmungen der StVZO und den hierzu vom Bundesminister für Verkehr und digitale Infrastruktur erlassenen heute gültigen Anweisungen und Richtlinien.

The vehicle part corresponds with the complete type description and meets current STVZO requirements, the present directions and directives passed by the Minister of Transport and digital infrastructure.

zur Erteilung eines Nachtrags zur ABE 91318 05
nach § 22 in Verbindung mit § 20 Straßenverkehrs-Zulassungs-Ordnung StVZO
*For the application of an amendment to German National Type Approval 91318*05
according to § 22 in connection with § 20 StVZO German Federal Road Traffic Standards)*

Fahrzeugteilart / <i>Vehicle part</i>	:	Laderaumabdeckung / <i>loading bay cover</i>
Typ / <i>type</i>	:	Mountain Top Roll
Antragsteller / <i>applicant</i>	:	Mountain Top Industries ApS, DK-3600 Frederikssund

5. Der Erteilung einer ABE stehen bei Einhaltung der in der Anlage 6./1 zur beigefügten Typbeschreibung vorgeschlagenen Auflagen und Hinweise technische Bedenken nicht entgegen.

There are no technical objections to the granting of a German national type approval mentioned above.

TÜV NORD Mobilität GmbH Co. KG
IFM - Institut für Fahrzeugtechnik und Mobilität
Schönscheidstr. 28, 45307 Essen
DIN EN ISO/IEC 17025, 17020

Benannt als Technischer Dienst / *Designated as Technical Service*
vom Kraftfahrt Bundesamt / *by Kraftfahrt-Bundesamt: KBA – P 00004-96*

Hannover, Germany 28.08.2017



A handwritten signature in black ink, appearing to read 'Baumeister'.

Dipl.-Ing. Baumeister

IFM - Institut für Fahrzeugtechnik und Mobilität
Test Laboratory Motor Vehicle Engineering

Auftragsnummer	8114944027
E-Mail	KBaumeister@tuev-nord.de
Telefon	+49 511 9986 1338

Typbeschreibung / type description

IFM - Institut für
Fahrzeugtechnik
und Mobilität

zum Gutachten vom 28.08.2017 zur Erteilung eines Nachtrags
zur ABE 91318 05 / as part of the test report dated 28.08.2017 for the
granting of an amendment to the German national type approval
91318 05



Fahrzeugteilart / vehicle part	:	Laderaumabdeckung / loading bay cover
Typ / type	:	Mountain Top Roll
Antragsteller / applicant	:	Mountain Top Industries ApS, DK-3600 Frederikssund

5. Anlagen / annexes

Aufgeführt sind alle mit diesem Nachtrag gültigen Anlagen, beigefügt sind lediglich die durch Fettdruck gekennzeichneten Anlagen / All attachments valid with this supplement are specified, attached documents are marked by bold print

		<u>Zeichnung Nr</u> <u>Drawing No.</u>	<u>Datum</u> <u>Date</u>
0./1	Laderaumabdeckung, alle Versionen <i>loading bay cover, all versions</i>	101696	17.08.2017
1./1	Verwendungsbereich, Gewicht (2 Seiten) <i>Range of Installation, weight (2 pages)</i>		28.08.2017
2./1	Fotoblatt / photo sheet		01.12.2011
3./1	Montageanleitung Mountain Top Roll 30 Seiten <i>Mounting instructions Mountain Top Roll (30 pages)</i>	MTI 886065	17.08.2017
6./1	Auflagen und Hinweise <i>conditions and instructions</i>		01.12.2011

28.08.2017

MOUNTAIN TOP ROLL - Int. Models

Vehicle			Mountain Top			
Manufacture/Trade name	Type approval no.	Type	MTI part no.	Variant	Year	Weight (kg)
FIAT						
Fullback	e1*2007/46*1398*00	KT0T	MTR FI 90	D/C	16-TD	31
Fullback	e1*2007/46*1398*00	KT0T	MTR FI 91	C/C	16-TD	36
FORD						
Ranger	e11*2007/46*0154*00	2AB	MTR FO 90	D/C	11-TD	31
Ranger	e11*2007/46*0154*00	2AB	MTR FO 91	X/C	11-TD	36
Ranger	e11*2007/46*0154*00	2AB	MTR FO 92	S/C	11-TD	44
Ranger	e11*2007/46*0154*00	2AB	MTR FO 90 H	D/C	11-TD	33
Ranger	e11*2007/46*0154*00	2AB	MTR FO 91 H	X/C	11-TD	38
Ranger	e11*2007/46*0154*00	2AB	MTR FO 92 H	S/C	11-TD	46
ISUZU						
D-Max	e4*2007/46*0321*00	TFR	MTR IS 90	D/C	12-TD	31
D-Max	e4*2007/46*0321*00	TFR	MTR IS 91	X/C	12-TD	36
D-Max	e4*2007/46*0321*00	TFR	MTR IS 92	S/C	12-TD	44
D-Max	e4*2007/46*0322*00	TFR	MTR IS 90	D/C	12-TD	31
D-Max	e4*2007/46*0322*00	TFR	MTR IS 91	X/C	12-TD	36
D-Max	e4*2007/46*0322*00	TFR	MTR IS 92	S/C	12-TD	44
ISUZU						
D-Max	e4*2007/46*0411*00	ATF	MTR IS 90	D/C	16-TD	31
D-Max	e4*2007/46*0411*00	ATF	MTR IS 91	X/C	16-TD	36
D-Max	e4*2007/46*0411*00	ATF	MTR IS 92	S/C	16-TD	44
MAZDA						
BT50	e11*2007/46*0155*00	UP	MTR MA 90	D/C	11-TD	31
BT50	e11*2007/46*0155*00	UP	MTR MA 91	X/C	11-TD	36
BT50	e11*2007/46*0155*00	UP	MTR MA 92	S/C	11-TD	44
MERCEDES-BENZ						
X Class	e9*2007/46*6531*00	4701	MTR MB 90	D/C	17-TD	33
X Class	e9*2007/46*6531*00	4701	A4708511100	D/C	17-TD	33
MITSUBISHI						
L200	e1*2007/46*1397*00	KJ0T	MTR MI 90	D/C	15-TD	31
L200	e1*2007/46*1397*00	KJ0T	MTR MI 91	C/C	15-TD	36
NISSAN						
Navara NP 300	e9*2007/46*6364*00	D231	MTR NI 90	D/C	15-TD	31
Navara NP 300	e9*2007/46*6364*00	D231	MTR NI 91	K/C	15-TD	36
RENAULT						
Alaska	e9*2007/46*6515*00	D231C	MTR RE 90	D/C	17-TD	31
Alaska	e9*2007/46*6515*00	D231C	MTR RE 91	K/C	17-TD	36
Alaska	e9*2007/46*6515*00	D231C	MTR RE 90T	D/C	17-TD	31
Ssangyong						
Actyon Sports	e4*2007/46*0330	QJ	MTR SS 90	D/C	17-TD	31
TOYOTA						
Hilux	e11*2007/46*0148*00	N2(EU,TSAM)	MTR TO 80	D/C	05-TD	31
Hilux	e11*2007/46*0148*00	N2(EU,TSAM)	MTR TO 82	S/C	05-TD	44
Hilux	e11*2007/46*0149*00	N2(EU,TMT)	MTR TO 80	D/C	05-TD	31
Hilux	e11*2007/46*0149*00	N2(EU,TMT)	MTR TO 81	X/C	05-TD	36
Hilux	e11*2007/46*0149*00	N2(EU,TMT)	MTR TO 82	S/C	05-TD	44

TOYOTA						
Hilux	e11*2007/46*2587*00	AN1P	MTR TO 90	D/C	15-TD	31
Hilux	e11*2007/46*2587*00	AN1P	MTR TO 91	X/C	15-TD	36
Hilux	e11*2007/46*2587*00	AN1P	MTR TO 92	S/C	15-TD	44
VW						
Amarok	e1*2007/46*0356*	2H	MTR VW	D/C	12-TD	35
Amarok	e1*2007/46*0356*	2H	MTR VW 80	D/C	09-TD	35
Amarok	e1*2007/46*0356*	2H	MTR VW 80 H	D/C	09-TD	35
Amarok	e1*2007/46*0356*	2H	MTR VW 82	S/C	11-TD	46

Explanations:

D/C = Double Cab
K/C = King Cab
C/C = Club Cab
X/C = Xtra Cab
S/C = Space or Single Cab
TD = To Day

NEW



Customer Service	+45 4810 2950 (08:00 - 16:00 CET)
Fax	+45 4810 2960
Support	info@mountaintop.dk
Website	www.mountaintop.dk
Address	Pedersholmparken 10, 3600 Frederikssund, Denmark